

TSA-251S

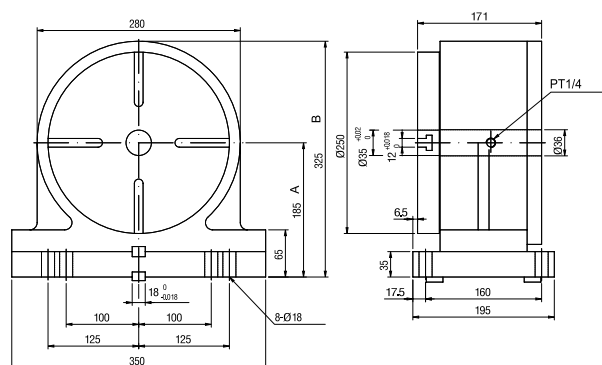

TSA-320S

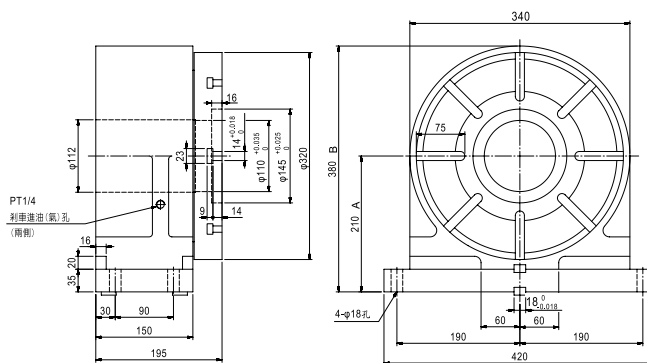

項目 / 型號	TSA-120S	TSA-200S	TSA-251S	TSA-320S
盤面直徑(mm)	ø120	ø200	ø250	ø320
(A) 垂直中心高(mm)	115	160	185	210
(B) 垂直全高(mm)	196	265	325	380
貫穿孔徑(mm)	ø30	ø35	ø35	ø110
T型槽寬(mm)	10 <sup>H7</sup>	12 <sup>H7</sup>	12 <sup>H7</sup>	14 <sup>H7</sup>
導槽寬(mm)	14 <sup>H7</sup>	18 <sup>H7</sup>	18 <sup>H7</sup>	18 <sup>H7</sup>
氣壓煞車扭力(kg•m)	15(動力源5kg/cm <sup>2</sup> )	25(動力源5kg/cm <sup>2</sup> )	65(動力源5kg/cm <sup>2</sup> )	80(動力源5kg/cm <sup>2</sup> )
油壓煞車扭力(kg•m)	25(動力源20kg/cm <sup>2</sup> )	50(動力源20kg/cm <sup>2</sup> )	115(動力源20kg/cm <sup>2</sup> )	150(動力源20kg/cm <sup>2</sup> )
淨重(kgs)	20	45	82	138
適用分度盤機型	CNC-120R	CNC-170R CNC-200R	CNC-250R CNC-320R CNC-400R	CNC-320R CNC-400R CNC-500R